



DR1000 | ROLLER SERIES

The DR1000 Series are high performance rollers suited for residential or commercial sliding window and door applications.

Manufactured with an engineered polymer outer carriage housing and passivated zinc inner carriage, this adjustable roller offers superior corrosion resistance and durability.

The DR1000 roller provides great performance and is moulded with a high performance engineered polymer that gives superior load rating and cycle testing.

ADVANTAGES

- Suits aluminium, timber and UPVC sliding doors
- Fully adjustable carriage gives 10mm height adjustment
- Outer carriage and internal assembly manufactured to withstand corrosive environments
- Polymer roller with bearing
- Roller 'ZZ' bearing with ground precision bearing for corrosion free operation
- Passivated metal inner carriage
- Recommended for sliding doors up to 100kg for the DR1000
- Stainless steel adjusting screw and nut width away from the pivot centre



PRODUCT DETAILS

OUTER CARRIAGE	Engineered polymer
INNER CARRIAGE	Cast zinc passivated
TYRE	DR71/DR73 high performance polymer with "ZZ" bearing and dust seal.
FINISH AVAILABLE	Black
MAX LOAD CAPACITY	50kg per carriage
CYCLE RATING	Tested to 30,000 cycles

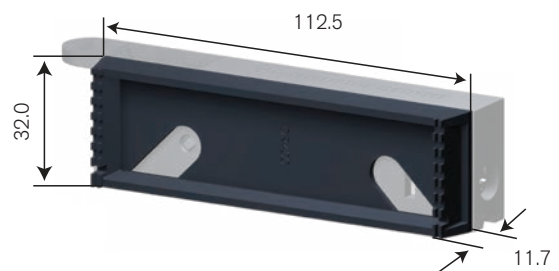

DR400 | Packer

SUITS	DR1000 & DR1009
MATERIAL	Engineered polymer
ADDS	11.7mm per packer
PRODUCT CODE	9042186

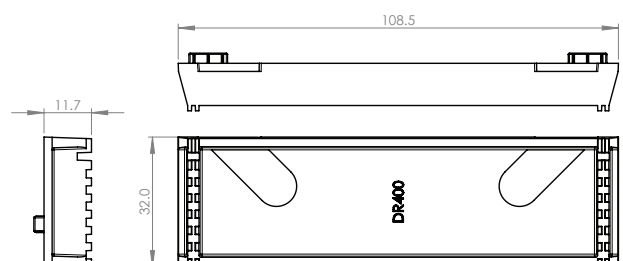

DR1000 | Adjustable Door Roller

ROLLER	WHEEL	WEIGHT RATING	ORDER CODE
Standard	DR71/ DR73	50kg max load	9036686

CARRIAGE	Engineered polymer outer Cast zinc passivated carriage
APPLICATION	Suitable for Aluminium Sliding Doors

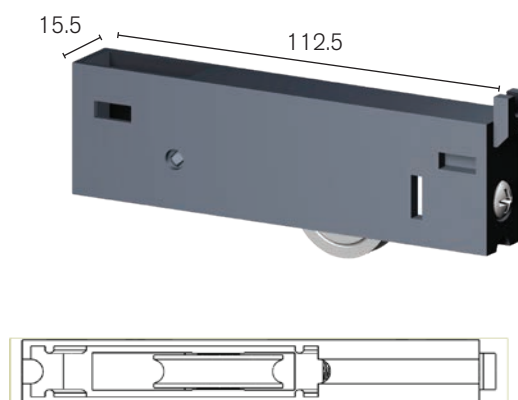

DR1003 | Adjustable Door Roller

ROLLER	WHEEL	WEIGHT RATING	ORDER CODE
Standard	DR71/ DR73	50kg max load	9033980

CARRIAGE	Engineered polymer outer Cast zinc passivated carriage
APPLICATION	Suitable for Aluminium Sliding Doors

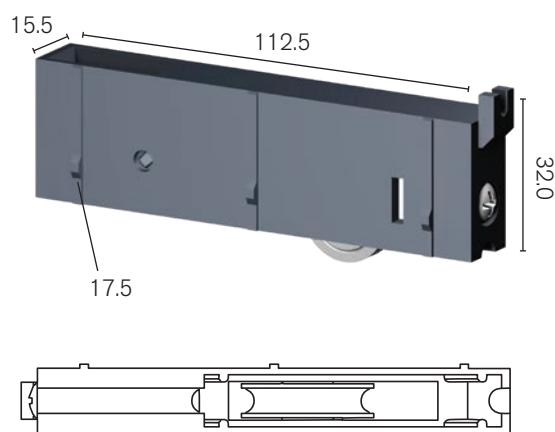

DR1009 | Adjustable Timber Door Roller

ROLLER	WHEEL	WEIGHT RATING	ORDER CODE
Standard	DR71/ DR73	50kg max load	9040456

CARRIAGE	Engineered polymer outer Cast zinc passivated carriage
APPLICATION	Suitable for Timber Sliding Doors

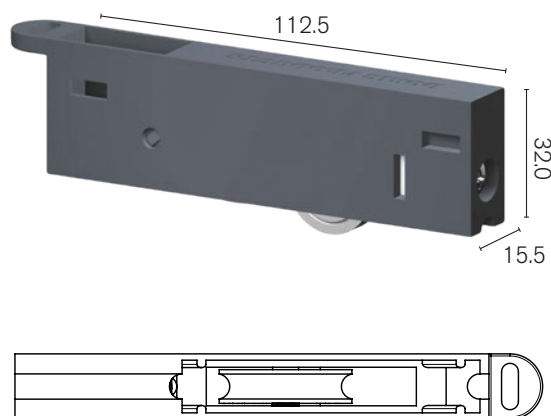

DR2000 | ROLLER SERIES

The DR2000 Series are high performance rollers suited for residential aluminium & timber door applications.

Manufactured with an engineered polymer outer carriage housing and passivated zinc inner carriage, this adjustable roller offers superior corrosion resistance and durability.

The DR2000 roller provides “ZZ” bearing performance rating and is moulded with a high performance engineered polymer that gives superior load rating and cycle testing.

ADVANTAGES

- Suits aluminium and timber sliding doors.
- Fully adjustable carriage gives 10mm height adjustment.
- Outer carriage and internal assembly manufactured to withstand corrosive environments.
- High performance roller with Doric's new Ryvelin tyre.
- Roller ZZ bearing with ground precision bearing with dust seal for corrosion free operation.
- Passivated metal inner carriage.
- Recommended for larger sliding doors up to 200kg.
- Stainless steel adjusting screw and nut.



PRODUCT DETAILS

OUTER CARRIAGE	Engineered polymer
INNER CARRIAGE	Cast zinc passivated
TYRE	DR71/DR73 high performance polymer with “ZZ” bearing and dust seal.
FINISH AVAILABLE	Black
MAX LOAD CAPACITY	100kg per carriage
CYCLE RATING	Tested to 30,000 cycles

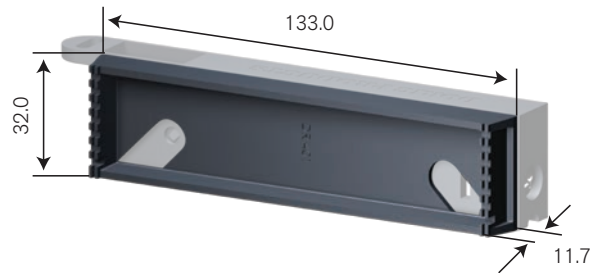

DR402 | Packer

SUITS	DR2000 & DR2009
MATERIAL	Engineered polymer
ADDS	11.7mm per packer
PRODUCT CODE	9042187

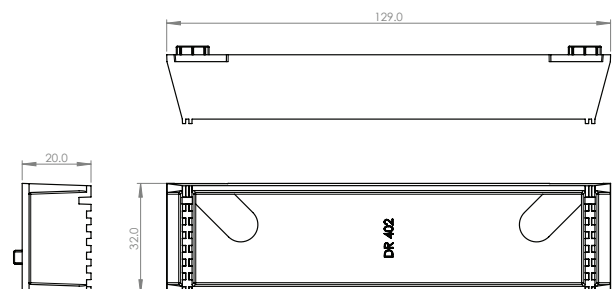

DR2000 | Heavy Duty Double Adjustable Door Roller

ROLLER	WHEEL	WEIGHT RATING	ORDER CODE
Standard	DR71/ DR73	100kg max load	9041707
Optional	DR2	40kg max load	9036637

CARRIAGE	Engineered polymer outer Cast zinc passivated carriage
APPLICATION	Suitable for Aluminium Sliding Doors

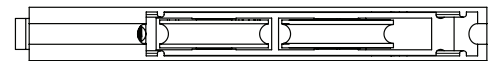
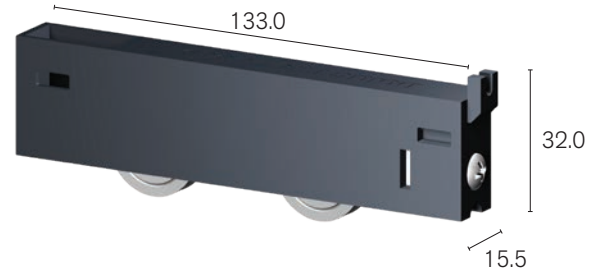

DR2003 | Heavy Duty Double Adjustable Door Roller

ROLLER	WHEEL	WEIGHT RATING	ORDER CODE
Standard	DR71/ DR73	100kg max load	9034035

CARRIAGE	Engineered polymer outer Cast zinc passivated carriage
APPLICATION	Suitable for Aluminium Sliding Doors

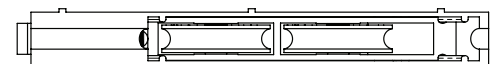
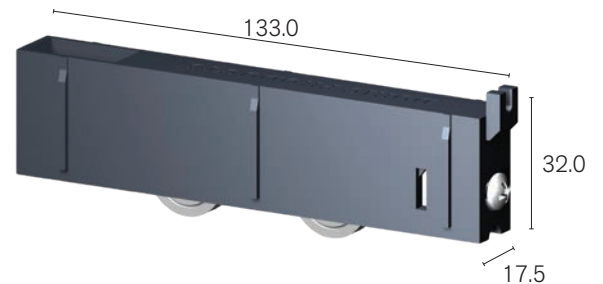

DR2009 | Heavy Duty Double Timber Door Roller

ROLLER	WHEEL	WEIGHT RATING	ORDER CODE
Standard	DR71/ DR73	100kg max load	9040457

CARRIAGE	Engineered polymer outer Cast zinc passivated carriage
APPLICATION	Suitable for Timber Sliding Doors

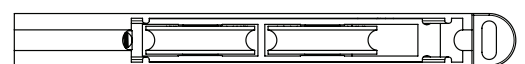
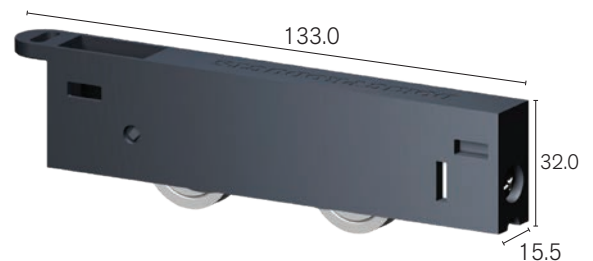

DR4000 | ROLLER SERIES

The DR4000 Quad Roller is a high performance roller carriage assembly consisting of 4 x "ZZ" precision bearing rollers with Ryvelin tyres for smooth operation and durability.

The combination of an engineered polymer outer carriage, stainless steel middle carriage and cast zinc inner carriage is designed to support door weights up to 280kg.

ADVANTAGES

- Fully adjustable carriage gives 8.5mm height adjustment.
- High performance rollers with ZZ bearing seal.
- Ryvelin tyres for smooth operation and durability.
- Stainless steel pivot pins and bearing axles.
- Maximum Carriage Load Rating 140kg (280kg Door).

PRODUCT DETAILS

OUTER CARRIAGE	Engineered polymer
INNER CARRIAGE	Cast zinc passivated
TYRE	DR71/DR73 high performance polymer with "ZZ" bearing and dust seal.
FINISH AVAILABLE	Black
MAX LOAD CAPACITY	140kg per carriage
CYCLE RATING	Tested to 30,000 cycles

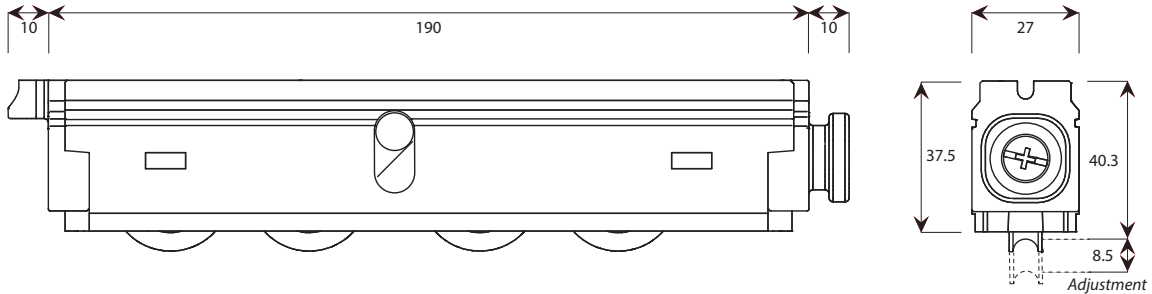

DR242 / DR246A / DR246B | ROLLER SERIES

ADVANTAGES

- Suitable for sliding windows & doors
- Engineered for smooth trouble free operation
- Fixed adjustment ensures sash will not drop over time
- Engineering Polly alloy carriages are corrosion free
- Bearings are manufactured from triple "A" Grade hardened high carbon steel - "AB" rated bearing
- Tyres are injection moulded in one piece and manufactured from Delrin
- Door rollers can be screw fixed into frames during assembly

PRODUCT DETAILS

ROLLER	Standard
CARRIAGE	Polly alloy

DR242

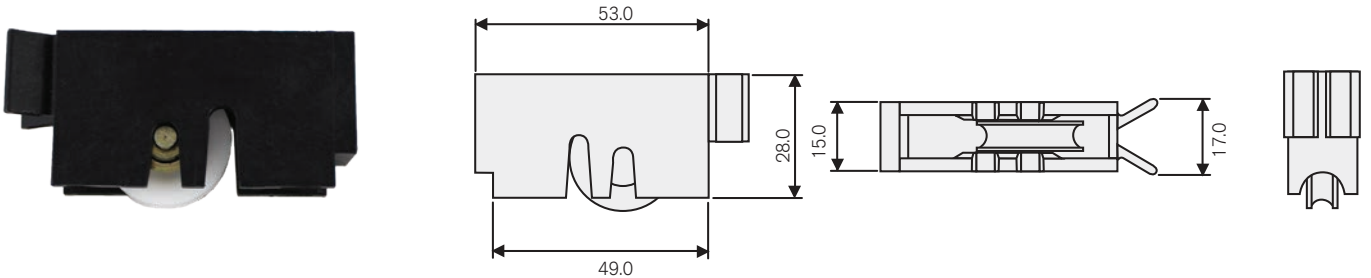

DR246A

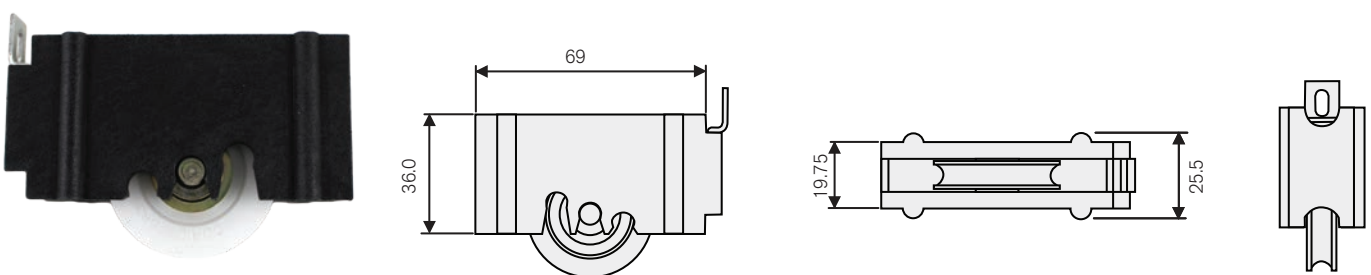

DR246B

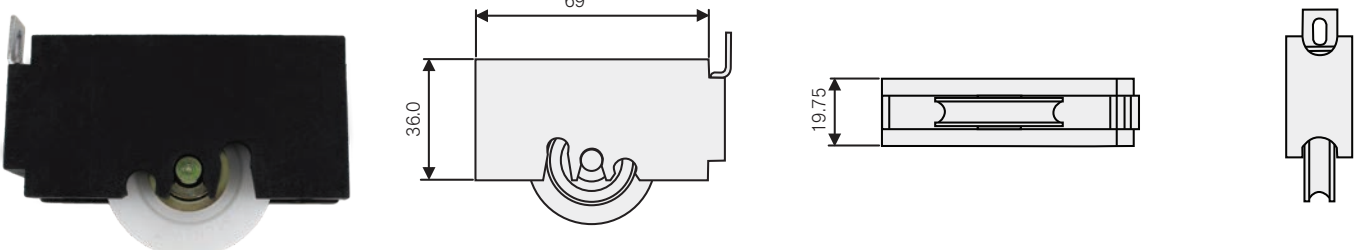

INNOVATORS

OF HARDWARE FOR WINDOWS AND DOORS

ROLLER_SERIES_DAP-v1.2-24.06.2020

SYDNEY

38 Redfern St,
Wetherill Park
Sydney, NSW 2164
Australia
Ph: +61 2 9609 2555
www.doric.com.au

AUCKLAND

26/C Triton Drive,
Albany, North Shore,
New Zealand 0632
Auckland
Ph: +64 9 415 5535
www.doricnz.co.nz

KUALA LUMPUR

No.17 Jalan 51/203A,
Kawasan Perindustrian Tiong Nam,
Seksyen 51, 46050 Petaling Jaya,
Selangor, Malaysia
Ph: +603 777 33 628
www.doric.com.my



DOOR | & WINDOW
ROLLERS